

EASIER. FASTER. INNOVATIVE.

THE IMPROVED IMS LIME SLAKER

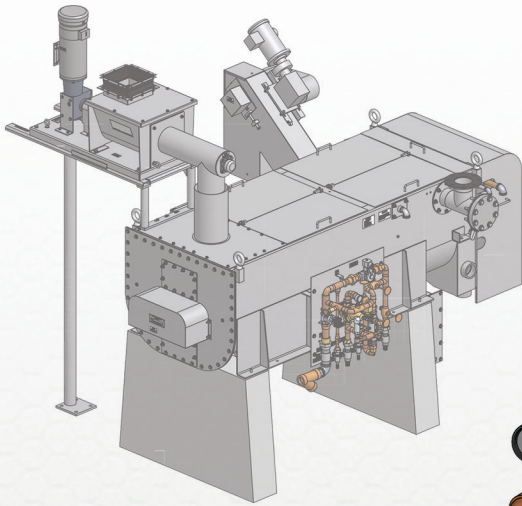

PRE-ASSEMBLED WATER PANEL

- Minimizes installation time
- Reduces manufacturing lead time
- Enables remote installation of water panel
- Makes maintenance easier
- Eases connection complexity
- Enhances slaker access
- Decreases risk of damage
- PVC or copper construction

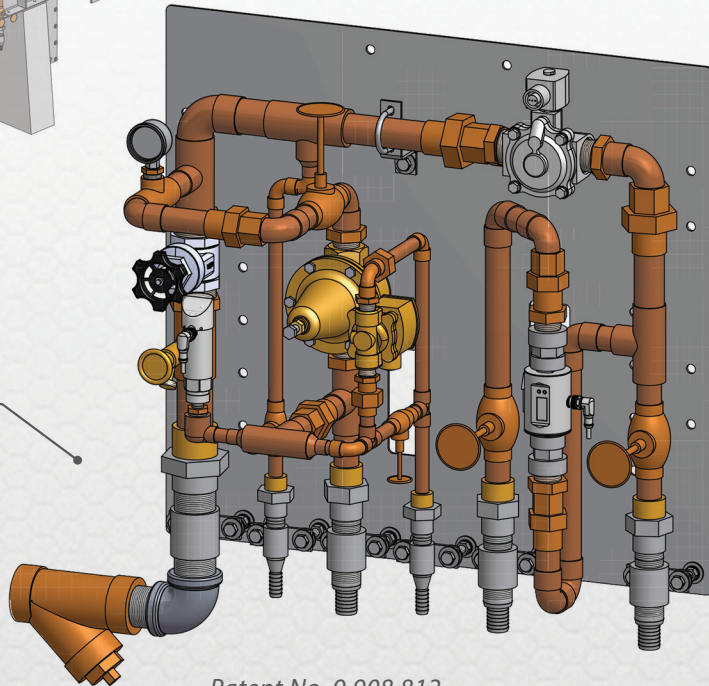

Patent No. 9,908,812



Integrity Municipal Systems
13135 Danielson St, Suite 204 Poway, CA 92064
www.integrityms.net | **phone** (858) 486-1620 | **fax** (858) 486-1659