

Integrity

MUNICIPAL SYSTEMS

Bulk Chemical Storage and Feed Systems & Lime Paste Slakers

Odor Control Systems: Biological, Chemical Scrubbers & Carbon Adsorbers

Packaged Chemical Feed Systems: Ammonia, Fluoride & Sodium Hypochlorite

Emergency Chlorine Scrubbers & Aftermarket Services

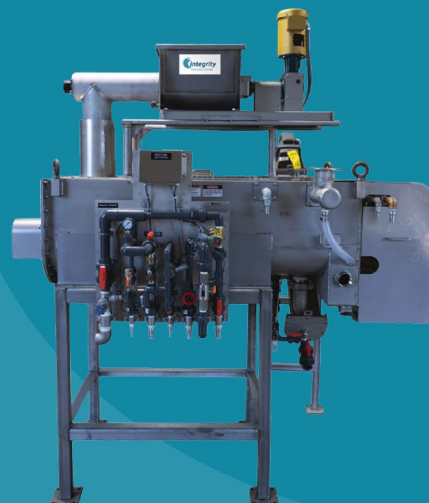

Engineering Excellence & Product Innovation

Bulk Chemical Storage and Feed Systems

Integrity Municipal Systems LLC (IMS) Bulk Chemical Storage and Feed System is used to store and feed dry Hydrated Lime, Quicklime, Powdered Activated Carbon (PAC), or Soda Ash in a silo, dissolve it in a tank, and pump the chemical solution to the point of application. Each system's design is tailored to the project's needs. Systems typically include a storage silo with accessories and an integral chemical feed equipment room with instrumentation and controls to make a complete and functional system.

IMS Silo Storage Benefits

- Pre-Assembled, Piped, Wired and Factory Tested
- Fully Engineered and Integrated Systems
- Single-Piece Welded Silo Construction (up to 14'-0" in diameter)
- Skirted Interior with Insulation, Lighting, Fans, Dampers, Louvers, and Heaters
- Completely Automatic Control System with PLC
- Flexible Configurations and Options for Differing Installation Requirements



BASIC SILO COMPONENTS

SIZES UP TO 14' DIAMETER

- Painted Carbon Steel
- Single-Piece Welded Construction

LADDER, CLIMBING PROTECTION SYSTEM AND TOP RAILS

- Galvanized Carbon Steel or Aluminum
- Per Current OSHA Standards

TRUCK UNLOADING OPERATOR STATION CONTROL PANEL

FILL LINE

- 4" SCH. 40 C/S with Quick Connect and Limit Switch

TARGET BOX WITH CLEANOUT PORT (ON ROOF)

MANWAY WITH INTEGRAL PRESSURE & VACUUM RELIEF VALVE (ON ROOF)

DUST COLLECTOR, AIR PULSE OR MECHANICAL SHAKER (ON ROOF)

LEVEL SWITCHES

- High, Re-Order, Low
- Rotating Paddle Type

DEHUMIDIFIER (ON ROOF) - Soda Ash Only

SILO SKIRT INTERIOR

SILO DISCHARGE

- Bin Activator
- Solid Cone with Vibrator

KNIFE GATE SHUTOFF VALVE

GRINDER/LUMP BREAKER - Soda Ash Only

ROTARY AIRLOCK FEEDER - PAC Only

FLEXIBLE FEEDER CONNECTOR

FEEDER

SLAKER, GRIT REMOVER AND SLAKER CONTROL PANEL - Quicklime Only

SLURRY TANK WITH MIXER & LEVEL CONTROL

- Optional for Quicklime System

FEED PUMP

WATER SUPPLY PANEL

MAIN SYSTEM CONTROL PANEL

SILO SKIRT ACCESSORIES INCLUDING:

- Double-Doors, Heater, Lights, Convenience Outlet, Vent Fan and Louver

OPTIONS

ANCHOR TEMPLATE

METAL FLOOR

- In-floor drain

INTERIOR INSULATION

RADAR CONTINUOUS LEVEL DETECTION

TRANSFER PACKAGE TO REMOTE DAY TANK

- Surge Hopper, Rotary Feeder, Blower, and Day Tank

PLC CONTROL

- Ethernet Communication With Plant Control System
- Single Pushbutton System Start and Stop

STRUCTURAL LEG SUPPORT OPTION

How It Works

The typical operation of the storage silo and solution feed system involves several basic steps:

1. Dry chemical is fed by pneumatic transfer into the silo
2. Dry chemical is then fed to a solution tank
3. Water is added to the solution tank for mixing and conversion of the dry chemical into a solution
4. Chemical solution is pumped to the process as required by the site operating conditions

Steps 2-4 are concurrent and, in the case of quicklime, Step 2 includes feeding dry quicklime to a paste-type lime slaking system. There, lime slurry is produced after slaking, then fed to a solution tank for storage.

The dry chemical is delivered to the jobsite by self-unloading, pneumatic bulk trucks. The truck connects to the inlet adapter on the silo fill pipe. The chemical is pushed up through the silo fill line by a pneumatic truck to the target box at the top of the silo to ensure even filling. The dust collector runs continuously to discharge the air and filter the dust to prevent dust emissions from leaving the silo.

Rotating paddle-type level switches monitor the chemical material level in the silo (High, Re-Order, Low). A truck unloading operator panel on the exterior of the silo provides controls for the silo fill operation.

The dry chemical is discharged by gravity through the silo. A bin activator at the bottom cone of the silo aids material flow and transfers vibrations to the material column without shaking the silo structure. A knife gate valve on the outlet of the bin activator allows positive cut-off of material flow between the bin activator outlet and the chemical feed equipment.

The feeder meters the dry chemical to the solution tank. The water addition is initiated by the system start signal: the water supply solenoid valve on a water panel opens, the feeder starts operating, and the solution tank mixer starts.

Solution production is controlled by a PLC with operator controls, a touch-panel mounted in the door of the chemical feed system control panel. After the solution has been completely mixed, a feed pump draws solution from the solution tank and meters the solution to the process.

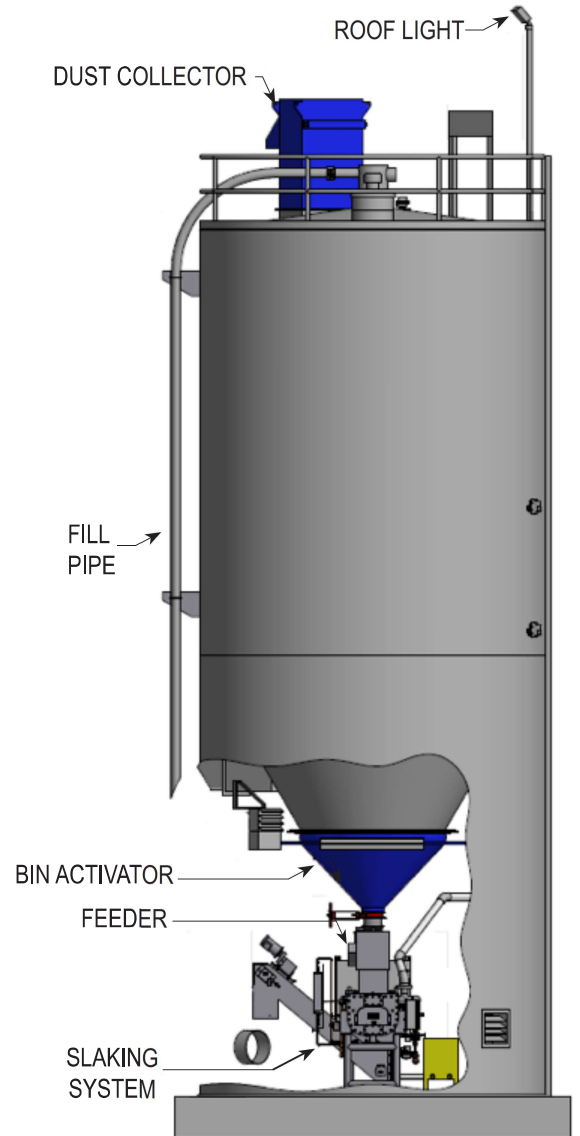

IMS Storage Silo
with Lime Slaker

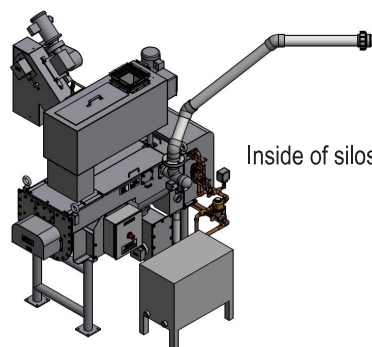

Inside of silos, showing slaking systems

Lime Slaker Systems (A-758™ & A-758 Plus™)

The IMS Lime Slaker Systems provide continuous high volume lime slurries (up to 8,000 lbs/hour) for industrial and municipal process pH adjustment, flocculation, and chemical reaction. The superior paste-type slaking technology consistently produces a higher strength and more reactive lime slurry resulting in more efficient and more economical use of the quicklime. Systems are factory assembled and tested for quick and easy installation, and include options for lime feed and grit removal.

IMS has built an inventory of 2,000 slaker parts. 90% of incoming orders are shipped within 24 hours.

Lime Slaker Systems - A-758™; A-758 Plus™

- 2:1 Water-to-Lime Slaking Ratio
- Robust Design - Built to Last
- Conveyor-Type, Screw-Type, or Vibrating Screen Grit Remover
- Volumetric or Gravimetric Belt-Type, or Volumetric Screw-Type Feeder
- Capacities: 1000, 2000, 4000, 8000 lb/hr
- Manual or Automatic Control
- Continuous or Batch Operation
- Pre-Assembled Water Panel Option
- More than 2,000 Parts in Inventory



Lime Slaker System: Feeders

Series 31-165 Gravimetric Feeder

- Accurate and reliable feeder operation
- Microprocessor controlled gravimetric feeding
- Accuracy better than 1% of feedrate
- Simple, straightforward man-machine interface
- Easy to install and maintain



Series 32-215 Volumetric Feeder

- Manual or automatic control
- Simple and straightforward volumetric feeding to 840 cu ft/hr (24 m³/hr)
- Easy to install and maintain
- Self-adjusting belt tracking



Series 32-300 Volumetric Feeder

- Heavy gauge construction
- Simple design
- Convenient controls and readouts
- Easy to install and maintain
- Smooth handling of difficult material flows



Lime Slaker System: Grit Removers

Conveyor Type Grit Remover

- Specific gravity classification of grit after water introduction
- Grit removal with chain and flight scrapers
- Fine degree of grit size control (10 mesh)
- Slurry concentrations up to 18% achievable
- Simple, reliable, and low maintenance



Screw Type Grit Remover

- Only one moving part
- Fine degree of grit size control (10 mesh)
- Slurry concentrations up to 18% achievable
- Low maintenance and simple service
- Simple and efficient operation

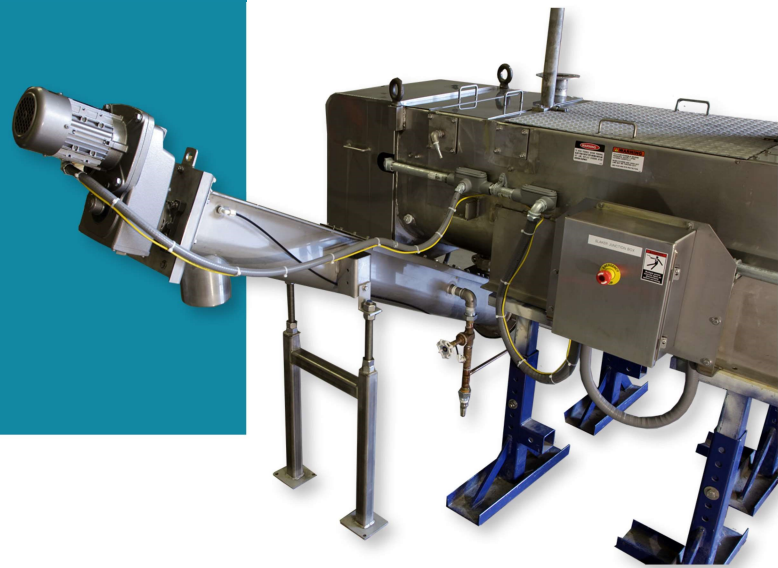

Screen Type Grit Remover

- Vibrating screen separator
- Positive grit removal by size (20 or 40 mesh)
- Slurry concentrations up to 20% achievable
- Optional (high) slurry concentration up to 28% available
- Small footprint and low profile



Lime Slaker System Improvements

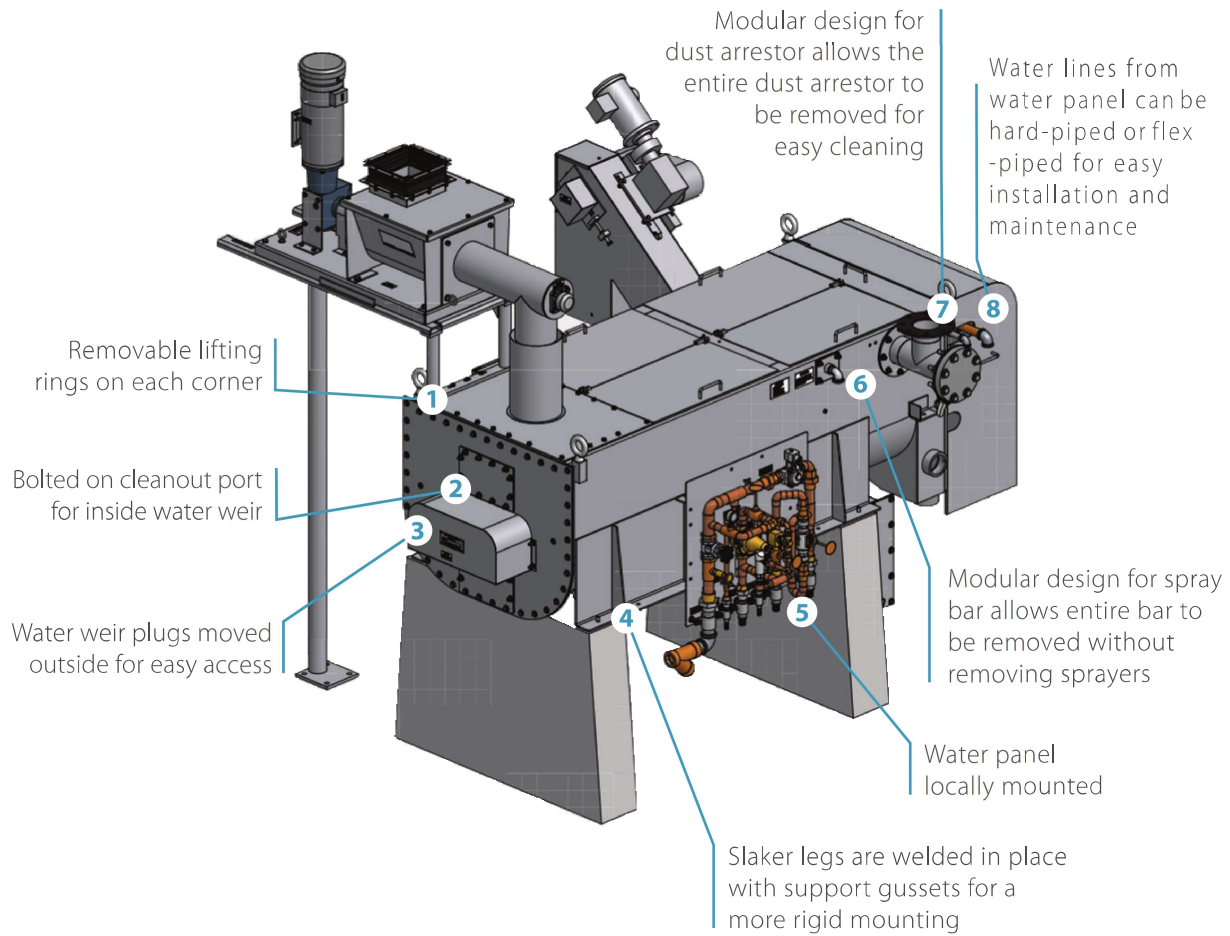

PVC or Copper Construction

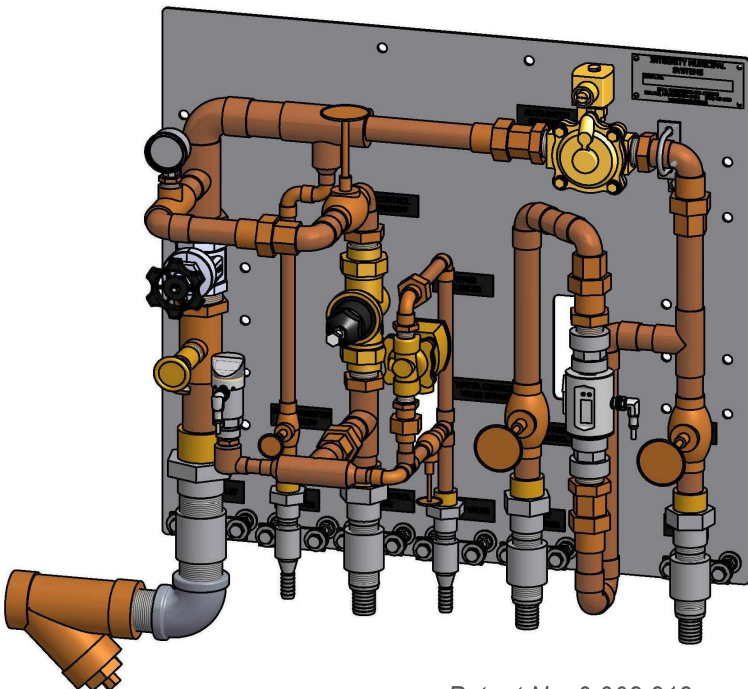

Pre-Assembled Water Panel

- Minimizes installation time
- Reduces manufacturing lead time
- Enables remote installation of water panel
- Makes maintenance easier
- Eases connection complexity
- Enhances slaker access
- Decreases risk of damage

Patent No. 9,908,812
Patent No. 10,494,297

Hose Connection Diagram for Paste-Type Lime Slaker System

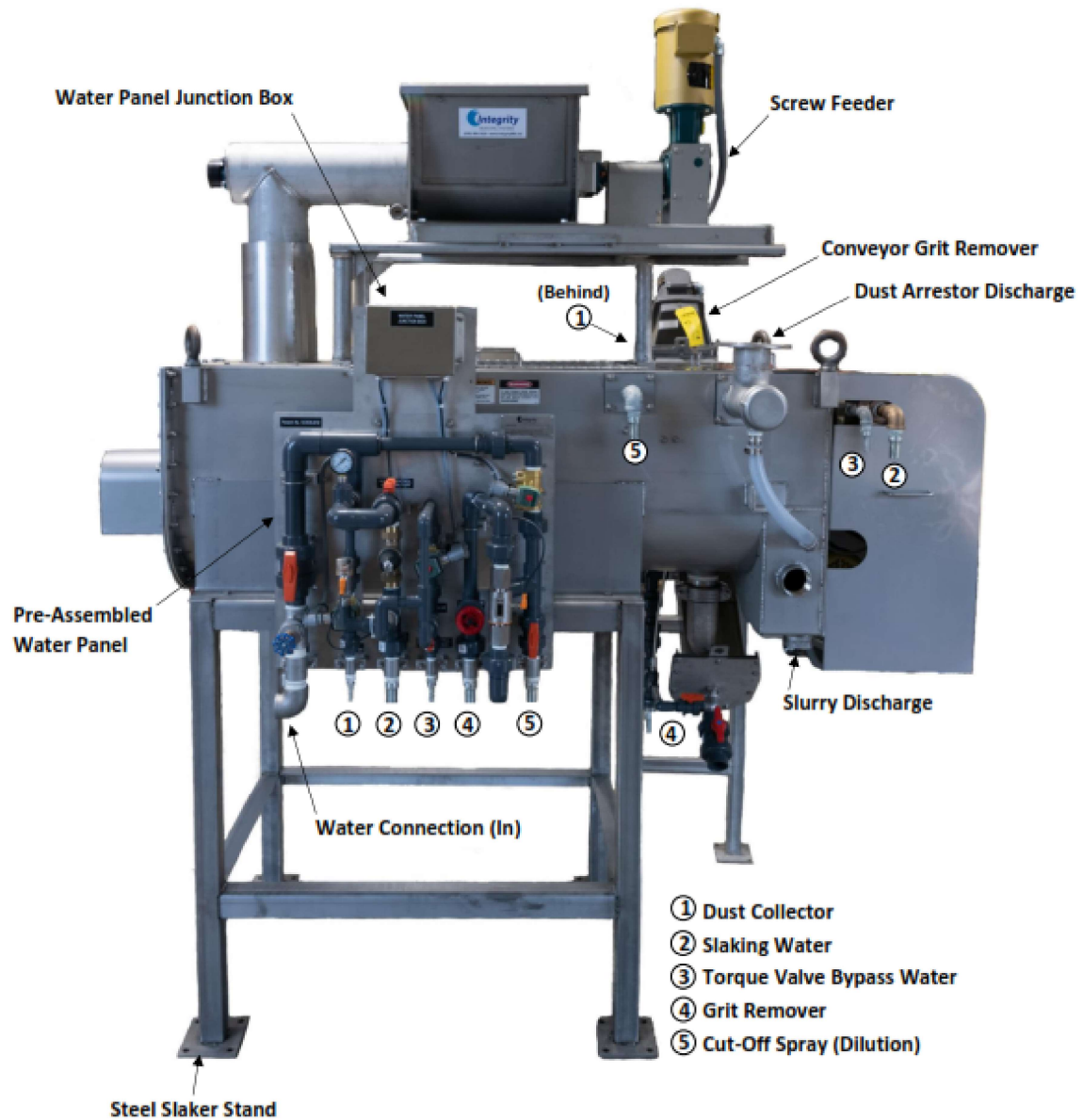

Pre-Assembled Water Panel

Patent No. 9,908,812

Patent No. 10,494,297

SGC-2000™ and SGC-2000 PLUS™ Gravimetric Feed Controllers



FEATURES & BENEFITS:

- Accurate and reliable gravimetric feeder control
- Allen-Bradley based industrial control hardware and software
- Limited number of interconnecting wires for easy installation and maintenance
- Simple and intuitive touchscreen interface
- Ethernet communications
- Optional Feeder AC motor use for reduced transformer size, heat generation, and energy consumption
- Optional VFD ODVA communication eliminates analog signal inaccuracies

The SGC-2000™ and SGC-2000 PLUS™ Gravimetric Feed Controllers control the feed rate for the Series 31-165 gravimetric feeder. The feeder controls include a touch screen for entering commands and parameters. Its menu driven software provides information regarding status, operational parameters, and alarm conditions. Alarm conditions displayed include: low and high feed rate, low and high belt load, low and high belt speed, setpoint and fault condition. The controller can be provided as a standalone controller (SGC-2000™) or as a complete package with VFD or SCR (SGC-2000 PLUS™).

Standalone Gravimetric Feed Controller with Load Cell Amplifier



- 24V DC, 120V, or 480V Options
- AC or DC Motor
- 16" x 16" x 8" NEMA 4X Box

Standalone Gravimetric Feed Controller with Load Cell Amplifier and VFD or SCR



- 120V or 480V Option
- AC or DC Motor
- 20" x 16" x 8" NEMA 4X Box

Odor Control Systems

IMS has developed a line of standardized, pre-engineered, factory assembled odor control systems for treating odors at sewage pump stations and wastewater treatment plants. Pre-engineered systems are simple to install, reducing the overall installed cost and delivery time.

Biological Odor Control Systems

The I-BOx[®] Biological Odor Control System (patent pending) uses a two-stage process with a biological stage to remove 99% of the hydrogen sulfide (H₂S), followed by an activated carbon polishing stage to remove residual H₂S and organic odors. Standard models are available to treat up to 5,000 cfm (8500 m³/h) of odorous air.



I-BOx[®]
350 - 5,000 cfm
(600 - 8,500 m³/h)

I-BOx[®] 350 - 5,000 cfm BIOLOGICAL ODOR CONTROL SYSTEM STANDARD MODEL DESIGN DATA

Model	Airflow Rate CFM (m ³ /h)	Overall Dimension (without stack) L x W x H ft (mm)	Inlet Connection Inches (mm)	Shipping Weight lbs (kg)	Operating Weight lbs (kg)	Fan Motor HP (kW)
I-BOx [®] 4000	Up to 350 (Up to 600)	6.5 x 4.0 x 9.5 (1980 x 1220 x 2900)	6.0 (150)	5,600 (2540)	6,000 (2700)	5.0 (3.7)
I-BOx [®] 5000	350-580 (600-1000)	7.5 x 5.0 x 9.5 (2285 x 1525 x 2900)	6.0 (150)	8,000 (3600)	8,500 (3850)	5.0 (3.7)
I-BOx [®] 6000	580-850 (1000-1450)	8.5 x 6.0 x 9.5 (2590 x 1830 x 2900)	7.0 (180)	9,000 (4082)	10,000 (4500)	5.0 (3.7)
I-BOx [®] 7000	850-1200 (1450-2100)	9.5 x 6.8 x 9.5 (2895 x 2083 x 2900)	7.0 (180)	11,500 (5216)	12,700 (5760)	5.0 (3.7)
I-BOx [®] 7010*	1200-1700 (2100-2900)	14 x 6.8 x 9.5 (4265 x 2083 x 2900)	12.0 (300)	19,500 (8845)	21,000 (9500)	5.0 (3.7)
I-BOx [®] 7015*	1700-2590 (2900-4400)	19.25 x 6.8 x 9.5 (5865 x 2083 x 2900)	16.0 (400)	28,500 (12927)	31,000 (14061)	5.0 (3.7)
I-BOx [®] 7020*	2590-3500 (4400-6000)	25.00 x 6.8 x 9.5 (7620 x 2083 x 2900)	16.0 (400)	37,500 (17010)	41,000 (18600)	7.5 (5.5)
I-BOx [®] 8000	1200-1500 (2100-2550)	12.00 x 8.0 x 9.5 (3658 x 2439 x 2900)	12 (300)	14,500 (6577)	16,000 (7257)	5.0 (3.7)
I-BOx [®] 8010	1500-2000 (2550-3400)	14.00 x 8.0 x 9.5 (4265 x 2439 x 2900)	16 (400)	19,000 (8618)	21,000 (9525)	5.0 (3.7)
I-BOx [®] 8015	2000-3000 (3400-5100)	19.25 x 8.0 x 9.5 (5865 x 2439 x 2900)	16 (400)	28,000 (12700)	31,000 (14061)	5.0 (3.7)
I-BOx [®] 8020	3000-4000 (5100-6800)	25.00 x 8.0 x 9.5 (7620 x 2439 x 2900)	16 (400)	37,000 (16783)	41,000 (18600)	7.5 (5.5)
I-BOx [®] 8025	4000-5000 (6800-8500)	29.75 x 8.0 x 9.5 (9068 x 2439 x 2900)	18 (457)	47,000 (21319)	52,000 (23587)	7.5 (5.5)

*The I-BOx[®] 7010, I-BOx[®] 7015 and I-BOx[®] 7020 are for use outside the USA.

I-BOx[®] Biological Odor Control System Benefits

- Two-stage, non-hazardous odor control process for H₂S and organic odor removal
- Airflow rate up to 5,000 CFM
- Compact footprint design
- “Plug & Play” installation
- Quiet & easy operation
- Single-piece construction
- Inert, non-hazardous media
- Superior non-corrosive materials
- Pre-assembled & factory tested
- Suitable for outdoor installation - optional weather enclosure



I-BOx[®] 75 - 250 cfm (125 - 425 m³/h)

I-BOx[®] 75 - 250 cfm BIOLOGICAL ODOR CONTROL SYSTEM STANDARD MODEL DESIGN DATA

Model	Airflow Rate CFM (m ³ /h)	Overall Dimension (without stack) Φ x H ft (mm)	Inlet Connection Inches (mm)	Shipping Weight lbs (kg)	Operating Weight lbs (kg)	Fan Motor HP (kW)
I-BOx [®] 30	Up to 75 (Up to 125)	2.5 x 7.6 (762 x 2316)	4.0 (100)	1,600 (726)	1,900 (862)	0.5 (.37)
I-BOx [®] 42	75-150 (125-255)	3.5 x 7.6 (1067 x 2316)	4.0 (100)	2,400 (1089)	2,700 (1226)	0.5 (.37)
I-BOx [®] 54	150-250 (255-425)	4.5 x 8.0 (1067 x 2438)	6.0 (150)	3,400 (1542)	4,100 (1860)	1.0 (.75)

Carbon Adsorber Odor Control Systems

The IMS carbon adsorber odor control systems are designed to work with a wide selection of media: virgin activated carbon media for low odor level, and high capacity carbon for higher H₂S concentrations.



MCS Benefits

- Superior non-corrosive material
- Easy to operate
- Suitable for outdoor installation
- Fan sound enclosure available
- Compact, skid-mounted design
- Pre-assembled and factory tested

The MCS carbon adsorber odor control systems are single bed, skid-mounted, dry media systems, designed for relatively lower odor levels. The media may be virgin activated carbon or any of a number of specialty catalytic carbon media. Standard models are available to treat up to 1,250 cfm (2,120 (m³/h)) of odorous air.

MCS ACTIVATED CARBON ODOR CONTROL SYSTEM STANDARD MODEL DESIGN DATA

Model	Airflow Rate CFM (m ³ /h)	Vessel Dimensions I.D. x SSH ft (mm)	Overall Dimensions (LxWxH) ft (mm)	Inlet Connection inches (mm)	Approx. Weight* lbs (kg)	Carbon Weight lbs (kg)	Fan Motor HP (kw)
MCS-018	110 (190)	18" x 54" (460 x 1370)	6'-0" x 3'-11" x 6'-0" (1830 x 1190 x 1830)	4 (100)	1000 (450)	160 (70)	1 (.75)
MCS-024	200 (340)	24" x 56" (610 x 1420)	6'-0" x 3'-11" x 6'-2" (1830 x 1190 x 1880)	6 (150)	1200 (550)	280 (130)	1 (.75)
MCS-030	300 (510)	30" x 56" (760 x 1420)	7'-0" x 4'-5" x 6'-2" (2130 x 1350 x 1880)	6 (150)	1500 (680)	440 (200)	2 (1.5)
MCS-036	425 (720)	36" x 58" (910 x 1470)	7'-0" x 4'-5" x 6'-5" (2130 x 1350 x 1960)	8 (200)	1700 (770)	640 (290)	2 (1.5)
MCS-042	600 (1020)	42" x 58" (1070 x 1470)	9'-1" x 5'-3" x 6'-5" (2770 x 1600 x 1960)	8 (200)	2300 (1040)	870 (390)	2 (1.5)
MCS-048	750 (1270)	48" x 60" (1220 x 1520)	9'-1" x 5'-3" x 6'-11" (2770 x 1600 x 2110)	10 (250)	2600 (1180)	1130 (510)	2 (1.5)
MCS-054	1000 (1700)	54" x 60" (1370 x 1520)	10'-1" x 6'-1" x 6'-11" (3070 x 1850 x 2110)	10 (250)	3200 (1450)	1430 (650)	3 (2.25)
MCS-060	1250 (2120)	60" x 62" (1525 x 1570)	10'-1" x 6'-1" x 7'-1" (3070 x 1850 x 2160)	12 (300)	3600 (1630)	1770 (800)	3 (2.25)

*Approximate weight is an estimate



BCS Benefits

- Superior non-corrosive material
- Easy to operate
- Suitable for outdoor installation

BCS System

The BCS activated carbon odor control systems are larger bulk media systems, designed for higher air flow rates. The media may be virgin activated carbon or any of a number of specialty catalytic carbon media. Standard models are available to treat up to 6,800 cfm (11600 m³/h) in a single carbon bed system and up to 20,000 cfm (34000 m³/h) in a dual bed system.

BCS ACTIVATED CARBON ODOR CONTROL SYSTEM STANDARD MODEL DESIGN DATA

Model	Carbon Bed(s)	Airflow Rate CFM (m ³ /h)	Overall Dimension L x W x H ft (mm)	Vessel Diameter ft (mm)	Shipping Weight lbs (kg)	Carbon Weight lbs (kg)	Fan Motor HP (kW)
BCS-600	Single	1000-1700 (1700-2900)	11 x 8 x 8 (3300 x 2400 x 2400)	6 (1800)	3500 (1600)	2600 (1200)	5 (3.7)
BCS-800	Single	1700-3000 (2900-5100)	15 x 10 x 8 (4500 x 3000 x 2400)	8 (2400)	6000 (2700)	4600 (2100)	7.5 (5.6)
BCS-1000	Single	3000-4700 (5100-8000)	17 x 12 x 8 (5100 x 3600 x 2400)	10 (3000)	9000 (4100)	7100 (3200)	10 (7.5)
BCS-1200	Single	4700-6800 (8000-11600)	20 x 14 x 8 (6000 x 4200 x 2400)	12 (3600)	13000 (5800)	10200 (4600)	15 (11.2)
BCS-1000D	Dual	6800-9400 (11600-16000)	19 x 12 x 13 (5700 x 3600 x 3900)	10 (3000)	17000 (7700)	14200 (6500)	20 (15)
BCS-1100D	Dual	9400-11400 (16000-19400)	20 x 13 x 13 (6000 x 3900 x 3900)	11 (3300)	20000 (9100)	17200 (7800)	20 (15)
BCS-1200D	Dual	11400-13600 (19400-23000)	21 x 14 x 13 (6300 x 4200 x 3900)	12 (3600)	24000 (10900)	20400 (9300)	25 (18.6)
BCS-1400D	Dual	13600-20000 (23000-34000)	23 x 16 x 13 (6900 x 4800 x 3900)	14 (4200)	32000 (14500)	27700 (12600)	40 (29.8)

Chemical Scrubber Odor Control Systems

IMS' Packaged Chemical Scrubber is a multi-stage high efficiency scrubber capable of promoting different chemical reactions in each stage and targeting a range of different compounds found in municipal Wastewater Treatment Plants and Pump Stations. The system is designed to be compact and low profile, enabling indoor or outdoor installation. IMS' chemical scrubber system is completely factory assembled for ease of installation treating airflow capacities up to 40,000 m³/h in a single system.

IMS' Packaged Chemical Scrubber is a "once-through", two-stage absorption system consisting of two vertical counter-current gas absorption sections.



CPS-3500

MAJOR COMPONENTS

- ❖ FRP Air Supply Fan
- ❖ FRP Vessel Inlet Transition Piece
- ❖ FRP Two-Stage Scrubber System
- ❖ Two Counter-Current Stage Gas Absorption System
- ❖ Two Integral Chemical Sumps
- ❖ Packing Media, Nozzles and Mist Eliminator
- ❖ Internal Piping and Access Doors
- ❖ Exhaust Stack
- ❖ PP Chemical Recirculation Pumps (vertical seal-less pumps)
- ❖ NaOH and NaOCl Metering Pumps
- ❖ Control Panel with Motor Starters
- ❖ pH, ORP and Level Controls
- ❖ Pressure & Differential Pressure Gauges

Chemical Scrubber System Benefits

- Reliable in the long term with robust design
- Minimized footprint and height required for the scrubber system and associated pumps and piping ductwork.
- Provides flexibility to customize the chemistry of each stage, to optimize the operating chemistry for actual plant odors, and to respond to process variations.
- Will make optimum use of chemical and minimize chemical costs.
- Will be delivered and installed quickly and smoothly, with minimum construction and installation cost and time.
- Will not require downtime for routine calibration and maintenance.
- Provides maximum value measured by effective odor control with minimum problems, maintenance and operating cost.

How It Works

The system utilizes Sodium Hydroxide (NaOH) and Sodium Hypochlorite (NaOCl) to react with and remove the odorous compounds present in the airstream. The foul air first enters a pre-conditioning stage (Stage 1) where it is contacted with liquid from the Stage 1 sump in a counter-current arrangement. The Stage 1 sump consists of a solution of fresh Sodium Hydroxide (NaOH) used to maintain the set pH. In the first stage, approximately 70 to 80% of the inlet hydrogen sulfide (H₂S) is removed. This configuration minimizes chemical costs by significantly reducing the amount of Hydrogen Sulfide that reacts with Sodium Hypochlorite.

After treatment in the first stage, the air travels through an integral baffle and enters the second counter-current scrubbing stage. In the second stage, the air is contacted with a water solution supplemented with a controlled amount of injected NaOH and NaOCl. This final stage assures the remaining odorous compounds are oxidized. Finally the “scrubbed” air is discharged from the system through a mist eliminator and into the atmosphere.



CHEMICAL SCRUBBER ODOR CONTROL SYSTEM STANDARD MODEL DESIGN DATA

Model	Airflow Rate CFM (m ³ /h)	Dimensions L x W x H ft (mm)	Overall Length (Including fan) ft (mm)	Shipping Weight lbs (kg)	Operating Weight lbs (kg)	Fan Motor HP (kw)	Recirc Pump Motors HP (kw)
CPS-2250	2200 (3700)	6.75 x 4.75 x 9.25 (2060 x 1450 x 2820)	12.5 (3810)	2500 (1100)	7000 (3200)	7.5 (5.6)	8.0 (6.0)
CPS-2500	2700 (4600)	7.50 x 5.00 x 9.50 (2290 x 1520 x 2900)	13.0 (3960)	3100 (1400)	8000 (3600)	7.5 (5.6)	8.0 (6.0)
CPS-2750	3300 (5600)	8.25 x 5.25 x 9.50 (2520 x 1600 x 2900)	15.0 (4570)	3700 (1700)	9500 (3200)	7.5 (5.6)	10.0 (7.5)
CPS-3000	4000 (6800)	9.00 x 5.50 x 10.50 (2740 x 1680 x 3200)	15.5 (4720)	4400 (2000)	11000 (5000)	10.0 (7.5)	10.0 (7.5)
CPS-3500	5500 (9300)	8.75 x 6.00 x 11.00 (2670 x 1830 x 3350)	16.0 (4880)	5000 (2300)	12000 (5500)	15.0 (11.0)	10.0 (7.5)
CPS-4000	7100 (12100)	10.00 x 6.50 x 11.00 (3050 x 1980 x 3350)	17.5 (5330)	5600 (2500)	14500 (6600)	16.0 (12.0)	12.5 (9.3)
CPS-4500	9100 (11500)	11.25 x 7.00 x 11.25 (3430 x 2130 x 3430)	19.5 (5940)	6200 (2800)	17000 (7700)	20.0 (15.0)	12.5 (9.3)
CPS-5000	11200 (19000)	12.50 x 7.50 x 11.50 (3810 x 2290 x 3500)	20.5 (6250)	6800 (3100)	19500 (8900)	25.0 (18.5)	15.0 (11.0)
CPS-5500	13600 (23100)	13.75 x 8.00 x 11.75 (4190 x 2440 x 3580)	22.0 (6700)	7500 (3400)	22000 (10000)	30.0 (22.0)	17.5 (13.0)
CPS-6000	16200 (27500)	15.00 x 8.50 x 12.00 (4570 x 2590 x 3660)	24.0 (7320)	8300 (3800)	22500 (11600)	40.0 (30.0)	17.5 (13.0)
CPS-6500	20000 (34000)	16.25 x 9.00 x 12.25 (4950 x 2740 x 3730)	26.0 (7930)	9100 (4100)	28500 (13000)	50.0 (37.3)	25 (18.6)
CPS-7000	24500 (41600)	17.50 x 9.50 x 12.50 (5330 x 2900 x 3810)	27.0 (8230)	10000 (4500)	32000 (14500)	60.0 (44.7)	35 (26.0)

Packaged Chemical Feed Systems

IMS chemical feed systems are pre-assembled, fully-functional chemical delivery systems for water treatment applications. These compact, user-friendly chemical skids include local storage tanks, full secondary containment, dosing pumps, instrumentation and controls. Systems are piped and wired at the factory for easy and quick hook-up.



Aqueous Ammonia Feed System

IMS packaged Aqueous Ammonia feed systems are used in the formation of chloramines for disinfection within the treated water pipelines and distribution system. They include a heavy duty pressure rated aqueous ammonia storage tank, integral ammonia fume scrubber, peristaltic dosing pump, instrumentation and controls in a fully contained, pre-assembled skid.



Fluoride Saturator and Feed System

IMS packaged Fluoride Feed Systems are used for community water fluoridation. They are designed with separate saturator and solution tanks to assure complete saturation, high reliability, low maintenance, and ease of use. Systems are sized to meet customer requirements.



Hydrofluosilicic Acid Feed System

IMS packaged Hydrofluosilicic Acid Feed Systems are used for community water fluoridation. They provide safe storage and accurate dosing of Hydrofluosilicic Acid, in a fully contained, pre-assembled skid. Packaged systems are pre-wired and piped with local instrumentation and controls.



Liquid Ammonium Sulfate (LAS) Saturator and Feed System

IMS packaged liquid ammonium sulfate (LAS) feed systems are used in the formation of chloramines for disinfection within the treated water pipelines and distribution system. IMS LAS Saturator and Feed System technology can reliably produce liquid ammonium sulfate solution from solid ammonium sulfate, decreasing chloramination chemical costs. The system is fully contained in a pre-assembled skid.



Sodium Hypochlorite Feed System

IMS packaged Sodium Hypochlorite Feed Systems are used as an alternative to gaseous chlorine to provide disinfection of the water at the water treatment plant and distribution system. They provide safe storage and controlled, accurate delivery of sodium hypochlorite solution, in a fully contained, pre-assembled skid. Systems may be customized to meet user needs.



Aqueous Ammonia Feed System

The IMS packaged Aqueous Ammonia Feed System includes a heavy-duty, pressure-rated, aqueous ammonia storage tank, integral ammonia fume adsorber, peristaltic dosing pump, instrumentation and controls in a fully contained, pre-assembled skid.

Optional enclosure, shown below, is ideal for outdoor or remote locations. The FRP shelter houses the equipment in an air conditioned environment and comes complete with lighting, ventilation fan, and breaker panel.



Aqueous Ammonia Feed System Benefits

- DOT authorized 428 kPa (62 psi) pressure rating
- Heavy-duty cylindrical tank for superior structural integrity
- Built-in ammonia fume adsorber prevents release of ammonia fumes to the atmosphere (no odor complaints)
- Pre-piped and wired for easy, low-cost installation
- Modular, portable design for easy relocation
- Compact small footprint (7 ft x 4 ft x 5 ft ht)
- Meets site specific requirements and provides desired features
- Metering pump capable of receiving and sending remote signals (4 to 20 mA input/output, remote start-stop, alarms)
- Robust design (with very low maintenance requirement)
- Fully contained to minimize risk of ammonium hydroxide solution entering floor drains
- High level switch in containment structure for local and remote alarm
- Equipped with ultrasonic level sensor with local display and remote transmission capability
- Integrated control panel with single point of connection by installer



Fluoride Saturator and Feed System

The IMS packaged Fluoride Feed System is designed with separate saturator and solution tanks to ensure complete saturation, high reliability, low maintenance, and ease of use. All systems are custom designed, with modular systems pre-assembled, factory-piped, -wired, and -tested in a compact design to meet customer requirements. Systems are fully contained with automated saturator operation and integrated control panel.

Optional enclosure, shown below, is ideal for outdoor or remote locations. The FRP shelter houses the equipment in an air conditioned environment and comes complete with lighting, ventilation fan, and breaker panel.



Fluoride Feed System Benefits

- Reduces or eliminates suspended solids in the solution tank and prevents dosing pump from plugging
- Very short installation time and low installation cost
- Reduces capital investment because of easy relocation, if desired
- Requires small footprint for installation
- Factory tested before delivery, significantly reducing system start-up time (~2 hrs)
- Meets site specific requirement and provides desired features
- Minimizes risk of sodium fluoride solution entering floor drains
- Level controls are pre-set for smooth saturator operation
- Single point of connection by installer



Hydrofluosilicic Acid Feed System

The packaged IMS Hydrofluosilicic Acid Feed System is used for community water fluoridation. They provide safe storage and accurate dosing of hydrofluosilicic acid, in a fully contained, pre-assembled skid. Packaged systems are pre-wired and piped with local instrumentation and controls.

Optional enclosure is ideal for outdoor or remote locations. The FRP shelter houses the equipment in an air conditioned environment and comes complete with lighting, ventilation fan, and breaker panel.



Hydrofluosilicic Acid Feed System Benefits

- Hydrofluosilicic acid FRP storage tank provides safe storage of hydrofluosilicic acid solution and is durable and corrosion resistant
- Pre-piped and wired for easy, low-cost installation
- Modular, portable design for easy relocation
- Compact small footprint
- Meets site specific requirements and provides desired features
- Factory tested before delivery, significantly reducing system start-up time (~2 hrs)
- Robust design (with very low maintenance requirement)
- Fully contained to minimize risk of hydrofluosilicic acid solution entering floor drains
- High level switch in containment structure for local and remote alarm
- Integrated control panel with single point of connection by installer
- Metering pump capable of receiving and sending remote signals (4 to 20 mA input, remote start-stop, alarms)
- Equipped with ultrasonic level sensor with local display and remote transmission capability

Liquid Ammonium Sulfate (LAS) Saturator and Feed System

The IMS packaged Liquid Ammonium Sulfate (LAS) Saturator and Feed System is used in the formation of chloramines for disinfection within the treated water pipelines and distribution system. IMS LAS Saturator and Feed System technology can reliably produce liquid ammonium sulfate solution from solid ammonium sulfate, decreasing chloramination chemical costs. The system is fully contained in a pre-assembled skid.

Optional enclosure, shown below, is ideal for outdoor or remote locations. The FRP shelter houses the equipment in an air conditioned environment and comes complete with lighting, ventilation fan, and breaker panel.



LAS Saturator and Feed System Benefits

- Superior upflow saturator design ensures complete saturation, high degree of reliability, and very low maintenance requirements
- Separate saturator and solution tanks reduces or eliminates suspended solids in the solution tank and prevents dosing pump from plugging
- Very short installation time and low installation cost
- Modular, portable design for easy relocation
- Compact small footprint (5.5' ft x 2.5' ft x 5.75' ft ht)
- Meets site specific requirements and provides desired features
- Factory tested before delivery, significantly reducing system start-up time (~2 hrs)
- Robust design (with very low maintenance requirement)
- Fully contained to minimize risk of liquid ammonium sulfate solution entering floor drains
- Level controls are pre-set to allow smooth saturator operation
- Integrated control panel with single point of connection by installer



Sodium Hypochlorite Feed System

The IMS packaged Sodium Hypochlorite Feed System is used as an alternative to gaseous chlorine to provide disinfection of the water at the water treatment plant and distribution system. IMS packaged sodium hypochlorite feed system provides safe storage and controlled, accurate delivery of sodium hypochlorite solution, in a fully contained, pre-assembled skid. Systems may be customized to meet user needs.

Optional enclosure is ideal for outdoor or remote locations. The FRP shelter houses the equipment in an air conditioned environment and comes complete with lighting, ventilation fan, and breaker panel.

Customer Requirements

- 110V, single phase, 15 amp power to control panel
- 4 to 20 mA signal for Sodium Hypochlorite metering pump
- Sodium Hypochlorite solution to injection point

Sodium Hypochlorite Feed System Benefits

- Sodium hypochlorite storage tank provides safe storage of sodium hypochlorite solution and is durable and corrosion resistant (in HDPE or FRP)
- Pre-piped and wired for easy, low-cost installation
- Modular, portable design for easy relocation
- Compact small footprint
- Meets site specific requirements and provides desired features
- Factory tested before delivery, significantly reducing system start-up time (~2 hrs)
- Robust design (with very low maintenance requirement)
- Fully contained to minimize risk of sodium hypochlorite solution entering floor drains
- High level switch in containment structure for local and remote alarm
- Integrated control panel with single point of connection by installer
- Metering pump capable of receiving and sending remote signals (4 to 20 mA input, remote start-stop, alarms)
- Equipped with ultrasonic level sensor with local display and remote transmission capability

Emergency Chlorine Scrubbers

IMS wet emergency chlorine scrubber systems are designed to contain and treat accidental releases of chlorine gas. The scrubber systems are factory pre-assembled, piped, wired and tested.

Emergency Chlorine Scrubber Benefits

- System is assembled, piped, wired and tested at factory
- Easy to transport, handle and install
- Installation time of less than 8 hours
- Installation requires only provision of concrete pad, inlet ductwork, utility connections and fill of caustic soda
- Excess liquid to absorb heat of absorption for maximum chlorine release
- Low pressure recirculation of scrubber liquid enhances safety
- Three-stage chemical process ensures efficiency greater than 99.999%
- Random packing provides large surface area for gas-liquid contact
- Low profile with top and side access for easy maintenance
- Robust design with vertical seal-less pump for low maintenance
- Low horsepower for pump and fan motors
- System can run in manual mode for maintenance purposes and in fully automatic mode for standby emergency operation

EVS-150

The EVS-150 emergency chlorine scrubber is a multi-stage wet scrubber system designed to treat chlorine vapors from a bank of 150lb (70kg) chlorine cylinders, at leak rates of 28 lbs/min or more, exceeding the requirement of the Uniform Fire Code. The EVS-150 system is designed to maintain negative pressure in the chlorination and chlorine storage rooms, while limiting the atmospheric release of chlorine to less than 1 ppm.

The factory-assembled EVS-150 system is very compact, with low profile suitable for either indoor or outdoor installation.

EVS-150 EMERGENCY CHLORINE SCRUBBER STANDARD MODEL DESIGN DATA

System	Design Capacity lbs (kg)	Airflow Rate cfm (m ³ /h)	Caustic Volume Gallons (Liters)	Dimensions L x W x H ft (m)	Shipping Weight lbs (kg)	Operating Weight lbs (kg)	Pump Motor HP (kW)	Fan Motor HP (kW)
EVS-150-2	300 (135)	250 (425)	275 (1040)	7.0 x 3.0 x 4.8 (2.1 x 0.9 x 1.5)	1,000 (450)	4,000 (1800)	3.0 (2.2)	1.0 (0.75)
EVS-150-4	600 (270)	250 (425)	550 (2082)	7.0 x 3.0 x 6.5 (2.1 x 0.9 x 2.0)	1,500 (700)	7,500 (3400)	3.0 (2.2)	1.0 (0.75)
EVS-150-6	900 (400)	250 (425)	660 (2500)	7.0 x 3.0 x 7.5 (2.1 x 0.9 x 2.3)	2,000 (900)	9,200 (4200)	3.0 (2.2)	1.0 (0.75)

EVS-2000

The EVS-2000 emergency chlorine scrubber is a multi-stage wet scrubber system designed to treat up to three tons of chlorine vapor at leak rates of 100 lbs/min or more, exceeding the requirements of the Uniform Fire Code. The EVS-2000 system is designed to maintain negative pressure in the chlorination and chlorine storage rooms, while limiting the atmospheric release of chlorine to less than 1 ppm.

The factory-assembled EVS-2000 system is very compact, with low profile suitable for either indoor or outdoor installation.



EVS-2000C

The EVS-2000C emergency chlorine scrubber is a multi-stage wet scrubber system designed to treat up to one ton of chlorine vapor, at leak rates of 100 lbs/min or more, exceeding the requirements of the Uniform Fire Code. The EVS-2000C system is designed to maintain negative pressure in the chlorination and chlorine storage rooms, while limiting the atmospheric release of chlorine to less than 1 ppm.

The factory-assembled EVS-2000C system is very compact, with low profile suitable for either indoor or outdoor installation.

EVS-2000/EVS-2000C EMERGENCY CHLORINE SCRUBBER STANDARD MODEL DESIGN DATA

Model	Design Capacity lbs/ton (kg)	No. of Cylinders Online	Airflow Rate cfm (m ³ /h)	Caustic Volume Gallons (Liters)	Dimensions L x W x H ft (m)	Shipping Weight lbs (kg)	Operating Weight lbs (kg)	Pump Motor HP (kW)	Fan Motor HP (kW)
EVS-150-2	300 lbs (135)	2	250 (425)	275 (1040)	7.0 x 3.0 x 4.8 (2.1 x 0.9 x 1.5)	1,000 (450)	4,000 (1800)	3.0 (2.2)	1.0 (0.75)
EVS-150-4	600 lbs (270)	4	250 (425)	550 (2082)	7.0 x 3.0 x 6.5 (2.1 x 0.9 x 2.0)	1,500 (700)	7,500 (3400)	3.0 (2.2)	1.0 (0.75)
EVS-150-6	900 lbs (400)	6	250 (425)	660 (2500)	7.0 x 3.0 x 7.5 (2.1 x 0.9 x 2.3)	2,000 (900)	9,200 (4200)	3.0 (2.2)	1.0 (0.75)
EVS-2000	1 ton (907)	1	3,000 (5100)	2,100 (8000)	13.0 x 7.0 x 8.5 (3.9 x 2.1 x 2.4)	8,000 (3630)	29,500 (13400)	20 (15)	5 (3.7)
EVS-2000	2 ton (1814)	2	3,000 (5100)	3,900 (14800)	13.0 x 7.0 x 11.5 (3.9 x 2.1 x 2.5)	10,000 (4500)	50,000 (22700)	20 (15)	5 (3.7)
EVS-2000	3 ton (2722)	3	3,000 (5100)	5,900 (22350)	13.0 x 9.0 x 12.25 (3.9 x 2.7 x 3.7)	14,000 (6350)	74,000 (33500)	20 (15)	5 (3.7)
EVS-2000C	1 ton (1000)	1	3,000 (5100)	2,100 (8000)	18 x 6.8 x 7.6 (5.4 x 2.0 x 2.3)	8,000 (3630)	29,500 (13400)	20 (15)	5 (3.7)

A-758™ and A-758 Plus™ Paste-Type Lime Slaker Refurbishment Service

IMS provides A-758™ and A-758 Plus™ Paste-Type Lime Slaker refurbishment services to restore the slaker to its original condition. The refurbishment consists of reassembling and replacing components to restore the slaker to its originally manufactured state. Refurbishment of an old slaker provides significant cost savings compared to the purchase of a new slaker system. IMS can review a particular application to determine whether the slaker is a good candidate for refurbishment. Please visit our website for project case studies.



BEFORE

AFTER



BEFORE

AFTER

Slaker Refurbishment Process:

- Visual inspection of unit
- Photographic documentation of initial condition of unit
- Complete unit disassembly and tear-down
- Documentation of all reusable parts prior to cleaning
- Preparation of cost estimate for all parts that cannot be reused
- Cleaning, sandblasting, and repainting of reusable parts as needed
- Reassembly of unit using reconditioned reusable parts and new replacement parts
- Reassembly of unit using new hardware, plumbing, and conduit/wiring to match existing unit
- System Testing: complete system testing, if applicable
- QC inspection
- Supply of shipping crate
- Packaging of unit for shipment
- Shipment of unit to jobsite

Scrubber Acid Wash and Refurbishment Service

With over 30 years of experience in the design, operation, servicing, commissioning, operational testing, performance testing, parts supply and refurbishing of emergency chlorine scrubbers and chemical odor control scrubbers, the IMS field service team has the knowledge and dedication to tackle any issues that arise with your emergency chlorine scrubber and odor control systems. From routine maintenance to full system rebuilds, we get it done. Please visit our website for project case studies.

Scrubber Services:

- System Inspections
- Acid Washing
- Repairs and Upgrades (Refurbishment)
- Replacement Parts
- Monthly, Quarterly, and Annual Service Contracts

Emergency Chlorine Scrubber (1-3 ton capacity) Acid Wash Service and Refurbishment:

- Removal of the existing caustic
- Disposal of caustic
- Provision of necessary acid to clean the scrubber
- Disposal of acidic brine
- Disposal of rinse water
- Filling of scrubber with fresh caustic
- Scrubber repair
- Gel coat of scrubber
- Painting of main scrubber components

Bulk Chlorine Scrubber (> 3 ton capacity) Refurbishment:

- Total caustic management
- Complete system and tank acid wash
- Disposal of generated waste
- 3rd party FRP inspection
- FRP repair, re-lining and refurbishment
- 3rd party post-repair FRP inspection as necessary
- Repair/replacement of scrubber piping and accessories
- Gel coat FRP components, and painting of fan and recirculation pumps



AFTER



BEFORE



AFTER



BEFORE



AFTER



BEFORE



Corporate Headquarters

Contact Us

www.integrityms.net

info@integrityms.net

Corporate Headquarters

13135 Danielson St., Suite 204
Poway, CA 92064 USA

Phone: (858) 486-1620

Slaker Manufacturing

500 E. Washington Ave., Suite 80
Zeeland, MI 49464 USA

Phone: (858) 218-3751



Poway Manufacturing Facility



Zeeland Manufacturing Facility



About Us

Integrity Municipal Systems LLC (IMS) is a specialty engineering company devoted to the design and supply of innovative, pre-assembled, process solutions for the water and wastewater industry.

With over 25 years of systems engineering innovation and project execution experience, the IMS team has the knowledge and dedication to tackle your odor control and chemical feed needs. IMS has achieved a reputation for producing unique, practical, and cost-effective solutions for our customers. We are committed to providing quality, service, and overall value that exceed your expectations.

Integrity Municipal Systems® and I-BOx® are registered trademarks of Integrity Municipal Systems LLC. Integrity Municipal Systems LLC. ©2020. All rights reserved.