

The IMS BCS carbon adsorber is a once-through activated carbon odor removal system designed to treat hydrogen sulfide (H<sub>2</sub>S) and organic odors (VOCs) found in municipal wastewater collection systems and treatment processes. Systems can be designed for airflow capacities up to 6,800 CFM (11600 m<sup>3</sup>/h) in a single bed and up to 20,000 cfm (34000 m<sup>3</sup>/h) in a dual bed system. Systems are designed for continuous and automatic operation as well as manual operation as required.



BCS

## SUPERIOR PERFORMANCE MEDIA

The IMS carbon systems are designed to work with a wide selection of media:

- Virgin activated carbon media for low odor levels
- High capacity carbon for higher H<sub>2</sub>S concentrations

## MAJOR SYSTEM COMPONENTS

- FRP Exhaust Fan
- FRP Transition Duct
- FRP Inlet Damper
- FRP Carbon Adsorber Vessel and Exhaust Stack
- Activated Carbon Media
- Electrical Control Panel

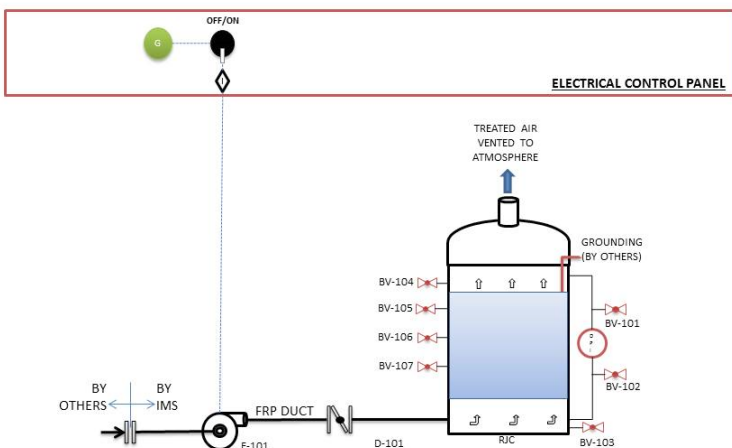

BCS Single-Bed Process & Instrumentation Diagram

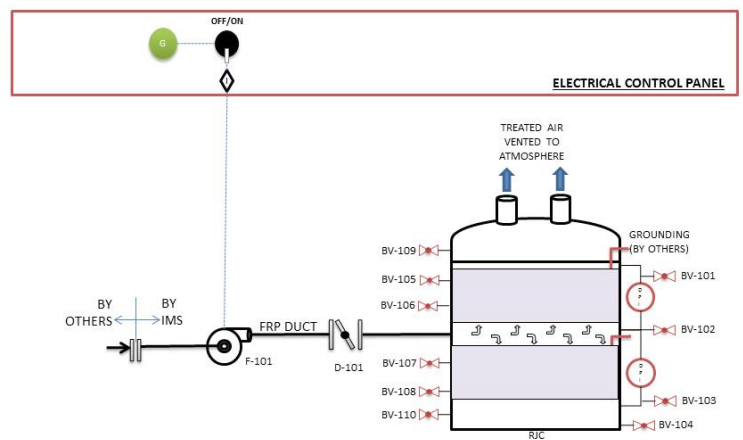

BCS Dual-Bed Process & Instrumentation Diagram

## HOW IT WORKS

The exhaust fan operates continuously, pulling foul air from the process area and passing it through the carbon media. A volume control damper at the system inlet allows regulation of airflow through the carbon adsorber.

Inside the vessel, the foul air flows through a densely packed bed of activated carbon. The odorous compounds are removed from the airstream through a combination of physical adsorption and chemisorption. Odorous compounds are physically adsorbed in the carbon pores, and some may undergo chemical reaction to form elemental sulfur and sulfuric acid. This process continues until the activated carbon pores are filled up and the odorous compounds break through and are released out the stack.

## SYSTEM FEATURES & BENEFITS

- Superior non-corrosive material
- Easy to operate
- Suitable for outdoor installation

## BCS ACTIVATED CARBON ODOR CONTROL SYSTEM STANDARD MODEL DESIGN DATA

Model	Carbon Bed(s)	Airflow Rate CFM (m <sup>3</sup> /h)	Overall Dimension L x W x H ft (mm)	Vessel Diameter ft (mm)	Shipping Weight lbs (kg)	Carbon Weight lbs (kg)	Fan Motor HP (kW)
BCS-600	Single	1000-1700 (1700-2900)	11 x 8 x 8 (3300 x 2400 x 2400)	6 (1800)	3500 (1600)	2600 (1200)	5 (3.7)
BCS-800	Single	1700-3000 (2900-5100)	15 x 10 x 8 (4500 x 3000 x 2400)	8 (2400)	6000 (2700)	4600 (2100)	7.5 (5.6)
BCS-1000	Single	3000-4700 (5100-8000)	17 x 12 x 8 (5100 x 3600 x 2400)	10 (3000)	9000 (4100)	7100 (3200)	10 (7.5)
BCS-1200	Single	4700-6800 (8000-11600)	20 x 14 x 8 (6000 x 4200 x 2400)	12 (3600)	13000 (5800)	10200 (4600)	15 (11.2)
BCS-1000D	Dual	6800-9400 (11600-16000)	19 x 12 x 13 (5700 x 3600 x 3900)	10 (3000)	17000 (7700)	14200 (6500)	20 (15)
BCS-1100D	Dual	9400-11400 (16000-19400)	20 x 13 x 13 (6000 x 3900 x 3900)	11 (3300)	20000 (9100)	17200 (7800)	20 (15)
BCS-1200D	Dual	11400-13600 (19400-23000)	21 x 14 x 13 (6300 x 4200 x 3900)	12 (3600)	24000 (10900)	20400 (9300)	25 (18.6)
BCS-1400D	Dual	13600-20000 (23000-34000)	23 x 16 x 13 (6900 x 4800 x 3900)	14 (4200)	32000 (14500)	27700 (12600)	40 (29.8)